

# POWERSHIFT AMT

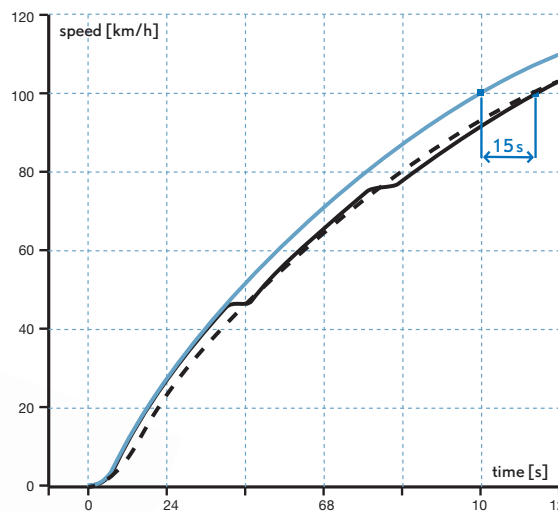

Converting a manual transmission into a cost-effective powershift automatic

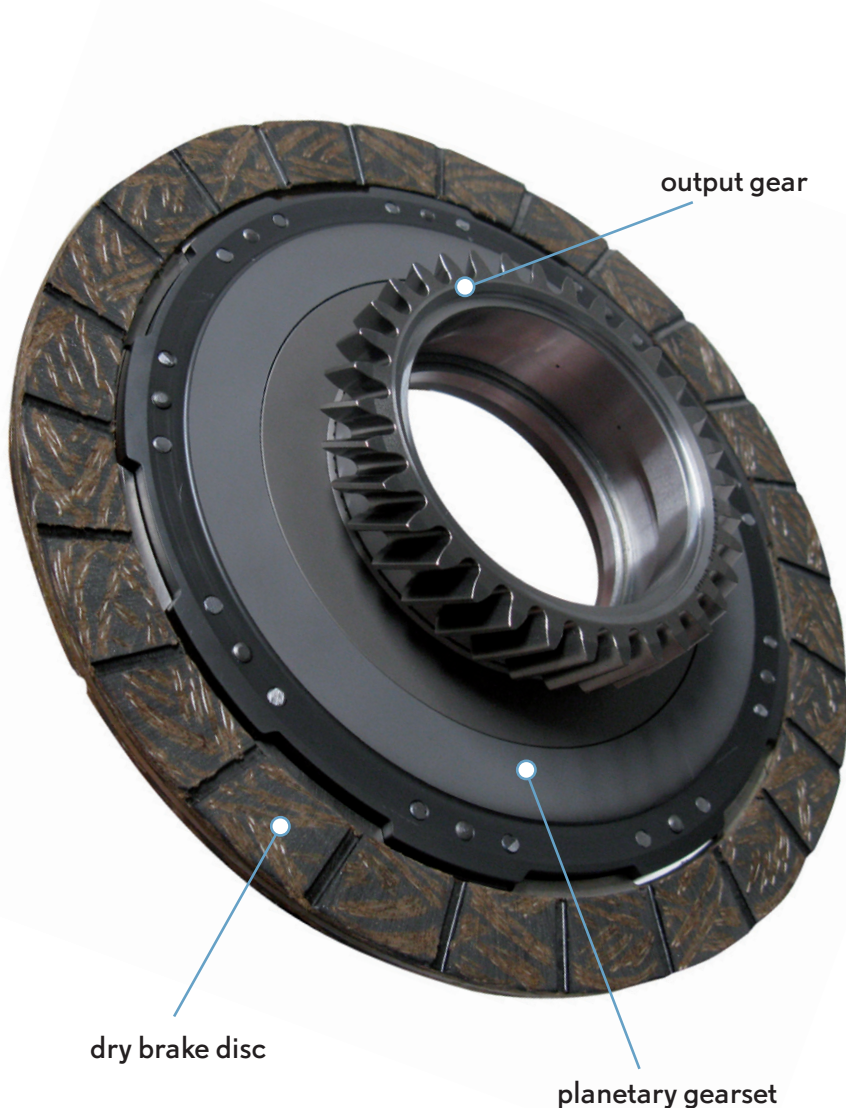

Acceleration 0-100km/h

- Powershift AMT
- AMT
- dry DCT

DTI developed a powershift unit that eliminates AMT shift gaps

The main benefits are:

- dry clutch & dry brake compound
- single clutch inertia
- packaged within standard (A)MT
- low cost solution
- low weight system

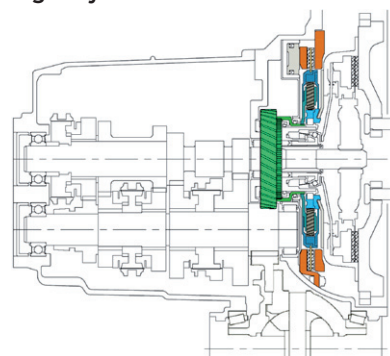

Drivetrain Innovations develops cost-effective and fuel saving transmission solutions.

Drivetrain Innovations BV  
Croy 46  
5653 LD Eindhoven  
The Netherlands  
tel. +31 40 2931082  
fax +31 40 2932885  
info@dtinnovations.nl  
www.dtinnovations.nl